

COMPANY PROFILE

LISA CONTROL TECHNOLOGY CO., LTD



2013



Content

Company information	1
History	2
Management	3
Human resources	4
Strategic Partners	5
Products	6
Services	7



DESIRING ALWAYS





Company information

Company name:	LISA Control Technology Co., ltd
Office:	Room 202, CT4A2, Bac Linh Dam urban, Dai Kim, Hoang Mai, Hanoi, Vietnam
Registered number	0101631040
Registered capital	250,000 USD
Establish year	2005
Tel/Fax:	+84 4 354 00982
Email:	contact@lisatech.vn
Website:	www.lisatech.vn



DESIRING ALWAYS





History and Milestone

- **Before 2005:** Schneider Steuerungstechnik GmbH in Germany opened a representative office in Vietnam to introduce LiSA lift controller according to European standards EN81, EN12015 và EN12016.
- **2005:** With elevator controller market opportunities in Vietnam, Schneider Steuerungstechnik GmbH decided to LiSA control technology co., ltd in Vietnam to distribute LiSA lift controller for local elevator manufacturers. LiSA control technology Vietnam was one of the first company supplier lift controller with German origin and European standards.
- **2007:** With Schneider Steuerungstechnik GmbH agreement, LiSA control technology Vietnam was owned 100% by our present Vietnamese local shareholders and became sole distributor for Schneider Steuerungstechnik GmbH products in Vietnam.
- **2007 to present:** LiSA control technology co., ltd expands the products and markets besides LiSA lift controller.
- Nowadays, LiSA Vietnam is a technical trading and services for some of most respected brand names in the worlds and we also has expanded our business to other Asian countries.



SCHNEIDER
STEUERUNGSTECHNIK GmbH



DESIRING ALWAYS





Management

Hội đồng quản trị
Board of Management

Ban giám đốc
General Directors

Phòng kỹ thuật
Engineering department

Phòng kinh doanh
Sales department

Phòng hành chính, kế toán
Admin & accountant dept

Nghiên cứu và phát triển
R&D team

Kỹ thuật kinh doanh
Pre-sales team

Hành chính
Administrative

Hỗ trợ kỹ thuật
Technical support team

Kinh doanh
Sales team

Kế toán
Accountant department

Thi công dự án
Site execution team

Hỗ trợ sau bán hàng
After-sales services team

Quản lý dự án
Project management team



DESIRING ALWAYS





Human Resources



Our most invaluable treasure and our pride are the human resources including management, design, customer support, manufacturing and installation teams with their talent and experience through many years working and training by famous brands.

We are always improving to make differences in the market by providing good quality products, safe and convenience to our customers.

Our engineers are practiced and trained regularly. Yearly, we have training courses in Vietnam or oversea with supports from our famous suppliers to make sure the talented technical team. With our project management experiences, engineering capabilities, unlimited creations, advance technologies and our dedicated people, we will bring the best quality products and services to customers.



DESIRING ALWAYS





Strategic Partners



Schneider Steuerungstechnik GmbH - Germany



LEONI Group - Switzerland



RIELLO UPS - Italy



ELIT S.R.L - Italy



SOJI technology co., ltd



Furutec Electrical Sdn. Bhd



Yaskawa Electric (Singapore) Pte Ltd



DESIRING ALWAYS





Main products

Application fields



SMT/PCB/AI Equipment



General Laboratory



Transport System



Factory Automation



Petrochemistry



OA / Office IT Equipment



Control Center/Data Center



Electronic & Medical Equipment



Aircraft Manufacturing



Air Bridge/Airport apron



Aircraft Maintenance Plant



Rotary Engine Manufacturing



Communication Equipment



Military Aircraft/ Helicopter



Navy System Diagnostics



Military Equipment



DESIRING ALWAYS





Main products

Frequency converter 50Hz/60Hz/400Hz

The static frequency converter allows to feed the aircraft on runway transforming the 50/60Hz mains voltage into a sinusoidal, stabilized and galvanic insulated 60Hz/50Hz/400Hz voltage. Application fields for Marines, Shipyard, airports, factories or laboratories.

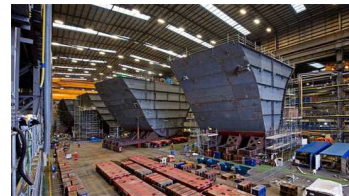
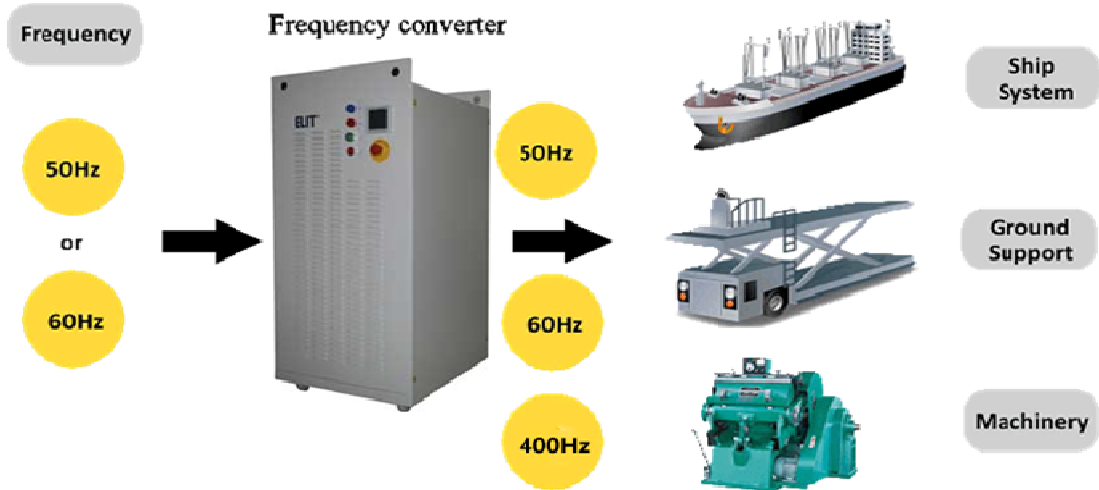

Partners

ELITAVIO
ELIT SISTEMI AEREOPORTUALI

ELITUPS
CONVERTITORI STATICI D'ENERGIA ELETTRICA

ELITLUCE
ELIT REGOLATORI PER ILLUMINAZIONE PUBBLICA



DESIRING ALWAYS



❖ Main products

Ground power unit 400Hz+28VDC

The static frequency converter allows to feed the aircraft on runway transforming the 50/60Hz mains voltage into a sinusoidal, stabilized and galvanic insulated 400Hz voltage and 28VDC (optional). The employ of the converter allows the electric system test, keeping OFF the aircraft's engines.



Partners

ELITAVIO
ELIT SISTEMI AEREOPORTUALI

ELITUPS
CONVERTITORI STATICI d'ENERGIA ELETTRICA

ELITLUCE
ELIT REGOLATORI PER ILLUMINAZIONE PUBBLICA



DESIRING ALWAYS



❖ Main Products

400Hz cables



BETAjet[®] 400 Hz cables are halogen free, most of them flame retardant and oil resistant, with improved fire performance and increased resistance to temperature. 400 Hz power supply systems provide the external power supply for aircraft on the ground. This system comprises both static cables in buildings as well as flexible connexions between buildings, passenger bridges, hangars, and the aircraft.

Partners

LEONI



DESIRING ALWAYS





Main products

Elevator lift controller

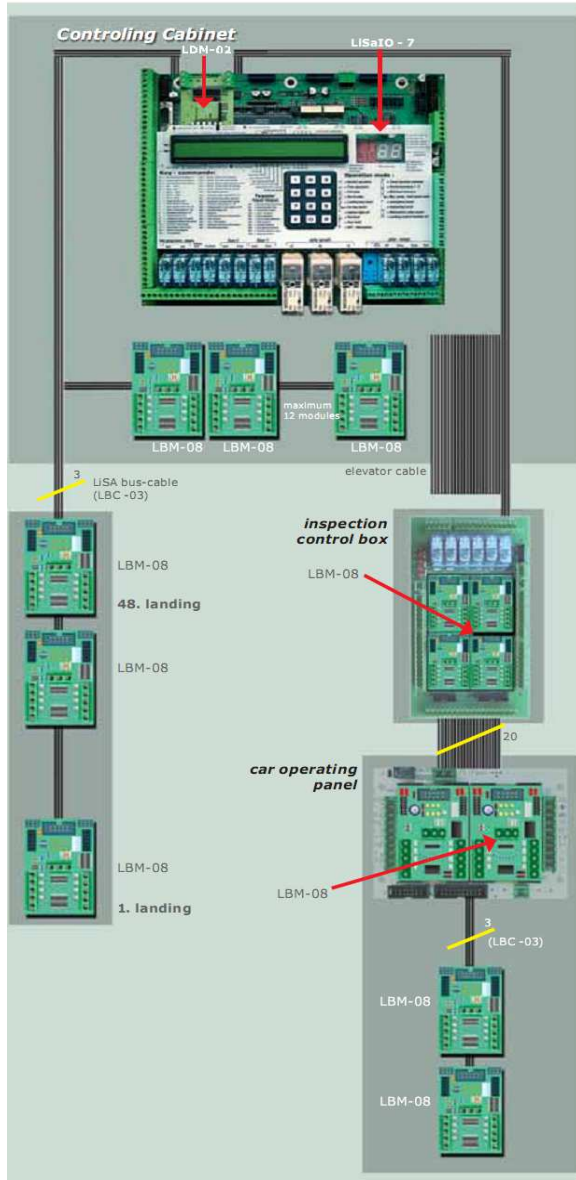

In 1990, Mr. Anton (German) founded the SCHNEIDER Steuerungstechnik GmbH. The beginning was the introduction and mass production of the first LiSA Microprocessor Controller Generation. With more than 24 years studying and working in Electrical and Elevator field, SCHNEIDER Steuerungstechnik GmbH obviously understand any problem of Elevator as well as its Controller. In 1985 one of the first single board Elevator Controller developed and Schneider Steuerungstechnik GmbH was after that set up in 1991, Schneider Elevator Controller with 2 Components System is now well know and favored by many elevator companies world wide. One of the function that has made Schneider controller outstanding is its high flexibility, easy integration with most kinds of elevator machinery, such as hydraulic lift, VVVF-traction lift, DC or AC gear-less lift etc. It is also easy and simple for new installation and modernization with minimum downtime, and very reliable.

LiSA Vietnam has been the sole distributor for Schneider Elevator Controller since 2005

Partners



SCHNEIDER
STEUERUNGSTECHNIK GmbH



DESIRING ALWAYS





Main products

Elevator automatic rescue devices

The ARD is a newest generation of emergency rescue device for elevator system to guarantee the return of cabinet to the nearest floor or bottom floor and open the door safely in the event of AC mains power failure, also in the case of power problem with lift itself. The smart CPU-based ARD can be installed with any type of control panel of elevator systems, it functions with sealed acid batteries and free maintenance. Easy installation and safe landing the cabinet for 100% security to the lift's operation.

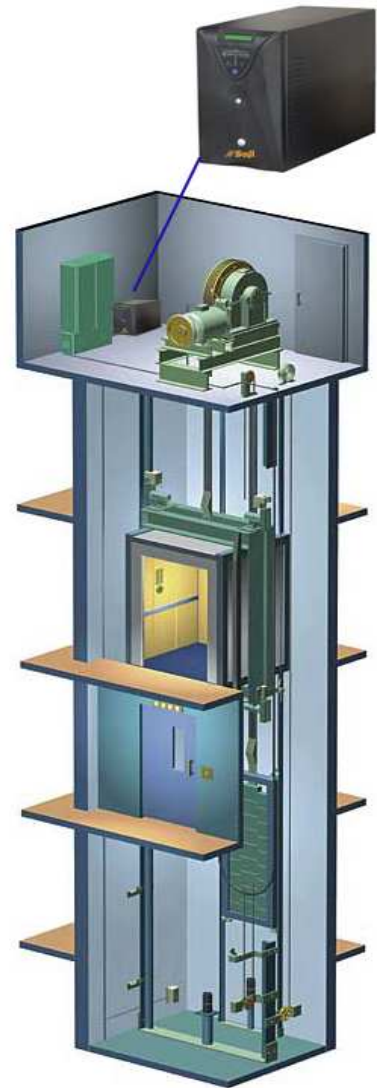

Connection of UPS for rescue operation (example)

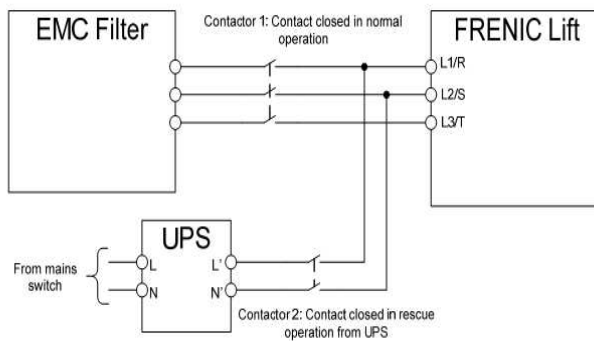

Partners



DESIRING ALWAYS





Main products

UPS, Inverter and Battery

We are authorized distributor for some of UPS, inverter, Static transfer switches, batteries. Product range is UPS 500VA to 800kVA



UPS single phase
500VA – 20kVA



UPS 3 phase
1kVA – 500kVA



Cabinet



Power distribution
cabinet



Battery

Partners



DESIRING ALWAYS





Main products

DC Power Supply and Rectifier

The feeder converts the main in dc voltage, performing the insulation between input and output. This type of working reduces the psfometric noise and the input distortion (clean energy), getting an high efficiency (energy saving). The microprocessor controls the output voltage, the current absorbed by the load and the batteries, disconnecting them when too discharged. The battery branch is independent by the power branch; it assures a perfect charge, optimizes the maintenance, guaranteeing a long life to the batteries. The output accuracy to 1% is insured for all back up time, till the total run down of the battery and their disconnection. The microprocessor control makes the Emergency Supply SE Series suitable to parallel connections without number limits. The mechanical assembly is realized to get the maximum safety and a nice industrial design..



DESIRING ALWAYS





Services



Our Services



Our services include:

- Site survey
- Design and consultation
- Installation and testing
- Regularly maintenance for systems
- Repair
- Remote monitoring
-

Our dedicated and well trained technical maintenance people are always 24/7 available.



DESIRING ALWAYS





LISA control technology co., ltd



Room 202, CT4A2, Bac Linh Dam, Dai
Kim, Hoang Mai, Hanoi 10000



+84 (0) 4 35400982 / +84 (0) 4 35400982



contact@lisatech.vn
www.lisatech.vn